

SONANCE

BEYOND SOUND

VISUAL EXPERIENCE SERIES

VX60R | VX80R

INSTALLATION AND SUPPORT MANUAL

VISUAL EXPERIENCE SPEAKERS

VX60R | VX80R

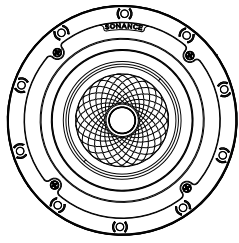

FRONT VIEW

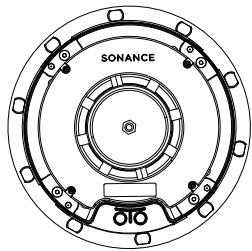

BACK VIEW

TABLE OF CONTENTS

- 2 Box Contents
- 2 Introduction
- 2 Important Safety Information
- 2 Installation
- 3 Grille Painting
- 4 Technical Specifications
- 5 Warranty

BOX CONTENTS

- (1) Cutout Template/Quickstart Guide
- (2) VX Model Speakers
- (2) Paintable Micro Trim Post Capture Grilles

INTRODUCTION

Thank you for selecting Sonance Visual Experience Speakers with Quadratech. Sonance has over four decades of experience in premium distributed audio. Please take the time to carefully read through the manual and study the illustrations. This extra time can lead to trouble-free operation and continued musical enjoyment.

IMPORTANT: Read this section in its entirety before attempting use of speaker.

IMPORTANT SAFETY INSTRUCTIONS

Always follow these basic safety precautions when using your speakers to reduce the risk of fire, electric shock, and injury to people or objects.

1. Read all the safety and operating instructions before operating the speaker and retain them for future reference.
2. Adhere to all warnings and precautions listed on the speaker and in the operating instructions.
3. Follow all operating instructions.

INSTALLATION

1. Determine the location for the speaker.
2. Perform an obstruction survey to be certain that there are no studs, conduit, pipes, heating ducts, pocket doors, or air returns in the wall cavity that will interfere with the speaker.
3. Position the included cutout template where the speaker is to be located and pencil an outline on the wall or ceiling. If you are unsure about obstructions, drill a small hole in the center of the outline and insert a coat hanger wire into the hole to feel-around for possible obstructions.
4. Cut the mounting hole using tools appropriate for the construction, and run the speaker wires from the mounting hole to the amplifier location.

IMPORTANT: Consult local building codes before running speaker wires through walls.

ONE-STAGE INSTALLATION

1. Strip 1/4" - 1/2" (6mm - 13mm) of insulation from each speaker lead. Twist the strands or tin the exposed wire with solder to ensure that there are no stray strands.

IMPORTANT: Stray strands that touch each other can cause a short-circuit that can damage the amplifier.

2. The speaker's connector posts are spring-loaded. Push the top of each connector post down to open the connector and insert the exposed wires into the holes in the posts (see Figure 1).

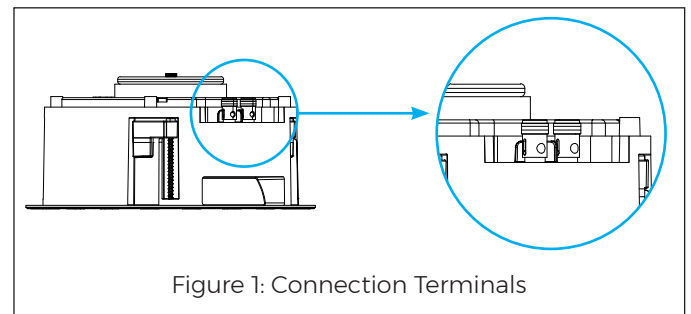

Figure 1: Connection Terminals

- The speaker's positive post is labeled with a red dot; the negative post is labeled with a black dot.
- After making all connections, double-check that you connected amplifier "+" to speaker "+" and amplifier "-" to speaker "-".

Sonance Visual Experience Series Speakers feature an exclusive integral RotoLock® mounting system for quick mounting directly into existing walls and ceilings.

- Make sure all the Roto-Lock toggle feet are retracted so that the speaker can fit within the mounting hole (see Figure 2).

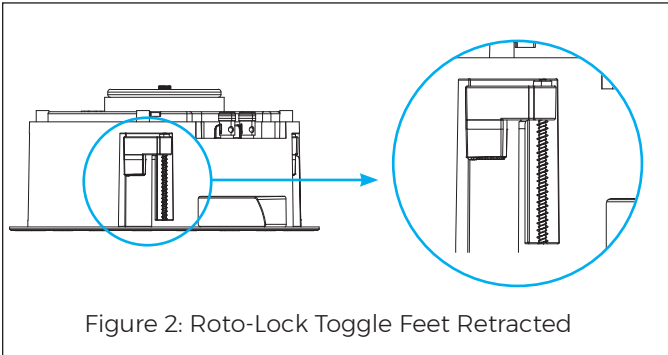

Figure 2: Roto-Lock Toggle Feet Retracted

- Insert the speaker into the mounting hole (see Figure 4) and tighten the four screws on the front of the speaker baffle (see Figure 5).

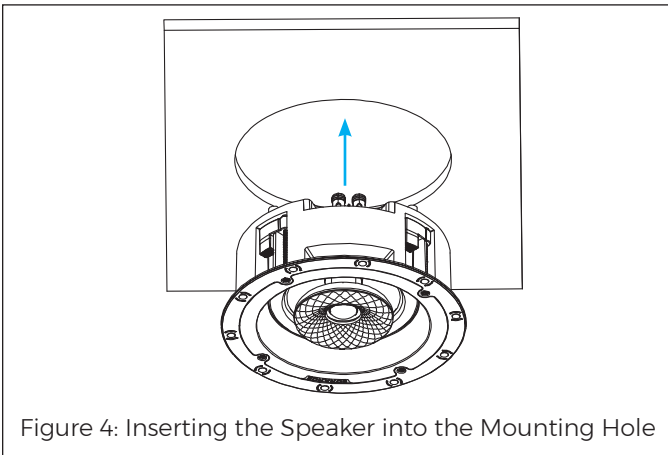

Figure 4: Inserting the Speaker into the Mounting Hole

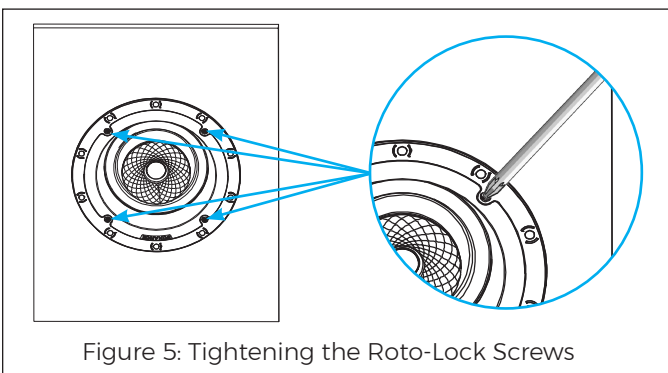

Figure 5: Tightening the Roto-Lock Screws

- The Roto-Lock clamps will automatically rotate into position and begin clamping the speaker.

IMPORTANT: Always use low-torque settings when using a screw gun and go slowly; never over tighten.

IMPORTANT: Adjusting the tension of the Roto-Lock Clamps to help the speaker sit flat with the surface will help ensure proper grille contact all the way around the speaker.

- Test audio playback by turning on the amplifier and source to play a signal to the speakers.
- The VX grille is held in place by several small, powerful magnets on the speaker frame. Place the grille against the speaker and the magnets will hold it firmly in place. When properly installed, the grille flange should make contact with the surface all the way around the speaker.

PAINTING THE GRILLES

Sonance Visual Experience Series speaker grilles completely cover the exposed speaker frame, so only the grilles (not the speakers themselves) require painting.

- Remove and save the scrim cloth from the back of the grille.
 - Prime the grille with a metal primer/bonder in a spray can. Carefully follow the manufacturer's directions on the can.
 - We recommend using water-based latex paint on the grilles. Thin the paint with a proper thinning agent to a ratio of 1:1 paint-to-thinner, and strain it through a standard mesh strainer to remove any lumps.
 - Use a small touch-up gun or cap-spray gun with a #3 tip for painting.
 - Set the nozzle with a medium to wide fan.
 - Set the pressure regulator to 60psi.
 - Lightly spray the front of the grille in three quick strokes from approximately 10" away.
 - Let the paint set for a minute, then turn the grille 90° and lightly spray the grille again in three quick strokes.
 - Repeat this step until all four sides of the grille have been evenly painted.
 - While the paint is still wet, inspect the grille and make sure that excess paint has not collected underneath the grille frame, and that none of the grille perforations are filled with paint. If any are, use compressed air to blow the paint out of the perforations.
- IMPORTANT: If you find any grille perforations that are plugged with paint after the paint has dried, use a straight pin or sewing needle to carefully remove the paint.**
- Optional step. Reattach the scrim cloth to the back of the grille once the paint has dried. You may need to use an extremely light single pass coating of 3M Super 76 spray adhesive.
 - Once the paint has thoroughly dried, mount the grille on the speaker.

TECHNICAL SPECIFICATIONS

VX60R

Tweeter	1" (25mm) cloth dome, Ferrofluid-cooled, acoustic back chamber
Woofer	6.5" (165mm) textured polypropylene cone, rubber surround
Dispersion Technology	Sinusoidal textured waveguide
Speaker Pivot	No Pivoting
Frequency Response	48Hz - 20kHz +/-3dB
Impedance	8 ohms nominal; 6 ohms minimum
Power Handling	5 watts minimum; 100 watts maximum
Sensitivity	89dB SPL
Mounting Technology	1-stage, 4 x RotoLock® Clamps
Round Micro Trim Grille (Dia)	9.62" (244.4mm)
Round Trimless Grille (Dia)	9.28" (235.6mm)
Square Micro Trim Grill (WxH)	9.62" x 9.62" (244.4mm x 244.4mm)
Square Trimless Grille (WxH)	9.28" x 9.28" (235.6mm x 235.6mm)
Speaker Mounting Depth (D)	4.13" (105mm)
Mounting Depth + Retrofit Encl.	5.75" (146.1mm)
Cut-Out Dims (Dia)	8.25" (210mm)
Shipping Weight	9 lbs. (4.1kg)

VX80R

Tweeter	1.2" (30mm) cloth dome, Ferrofluid-cooled, acoustic back chamber
Woofer	8" (203mm) textured polypropylene cone, rubber surround
Dispersion Technology	Sinusoidal textured waveguide
Speaker Pivot	No Pivoting
Frequency Response	42Hz - 20kHz +/-3dB
Impedance	8 ohms nominal; 6 ohms minimum
Power Handling	5 watts minimum; 125 watts maximum
Sensitivity	90dB SPL
Mounting Technology	1-stage, 4 x RotoLock® Clamps
Round Micro Trim Grille (Dia)	11.52" (292.6mm)
Round Trimless Grille (Dia)	11.17" (283.8mm)
Square Micro Trim Grill (WxH)	11.52" x 11.52" (292.6mm x 292.6mm)
Square Trimless Grille (WxH)	11.17" x 11.17" (283.8mm x 283.8mm)
Speaker Mounting Depth (D)	4.69" (119mm)
Mounting Depth + Retrofit Encl.	6.52" (165.6mm)
Cut-Out Dims (Dia)	10.125" (257mm)
Shipping Weight	12.5 lbs. (5.67kg)

LIMITED FIVE (5) YEAR WARRANTY

Sonance warrants to the first end-user purchaser that this Sonance-brand product (Sonance Visual Experience Speaker) when purchased from an authorized Sonance Dealer/Distributor, will be free from defective workmanship and materials for the period stated below. Sonance will at its option and expense during the warranty period, either repair the defect or replace the Product with a new or remanufactured Product or a reasonable equivalent.

EXCLUSIONS: TO THE EXTENT PERMITTED BY LAW, THE WARRANTY SET FORTH ABOVE IS IN LIEU OF, AND EXCLUSIVE OF, ALL OTHER WARRANTIES, EXPRESS OR IMPLIED, AND IS THE SOLE AND EXCLUSIVE WARRANTY PROVIDED BY SONANCE. ALL OTHER EXPRESS AND IMPLIED WARRANTIES, INCLUDING THE IMPLIED WARRANTIES OF MERCHANTABILITY, IMPLIED WARRANTY OF FITNESS FOR USE, AND IMPLIED WARRANTY OF FITNESS FOR A PARTICULAR PURPOSE ARE SPECIFICALLY EXCLUDED.

No one is authorized to make or modify any warranties on behalf of Sonance. The warranty stated above is the sole and exclusive remedy and Sonance's performance shall constitute full and final satisfaction of all obligations, liabilities and claims with respect to the Product.

IN ANY EVENT, SONANCE SHALL NOT BE LIABLE FOR CONSEQUENTIAL, INCIDENTAL, ECONOMIC, PROPERTY, BODILY INJURY, OR PERSONAL INJURY DAMAGES ARISING FROM THE PRODUCT, ANY BREACH OF THIS WARRANTY OR OTHERWISE.

This warranty statement gives you specific legal rights, and you may have other rights which vary from state to state. Some states do not allow the exclusion of implied warranties or limitations of remedies, so the above exclusions and limitations may not apply. If your state does not allow disclaimer of implied warranties, the duration of such implied warranties is limited to period of Sonance's express warranty. Your Product Model and Description: Sonance Visual Experience Speaker. Warranty Period for this Product: Five (5) years from the date on the original sales receipt or invoice or other satisfactory proof of purchase.

Additional Limitations and Exclusions from Warranty Coverage: The warranty described above is non-transferable, applies only to the initial installation of the Product, does not include installation of any repaired or replaced Product, does not include damage to allied or associated equipment which may result for any reason from use with this Product, and does not include labor or parts caused by accident, disaster, negligence, improper installation, misuse (e.g., overdriving the amplifier or speaker, excessive heat, cold or humidity), or from service or repair which has not been authorized by Sonance.

Obtaining Authorized Service: To qualify for the warranty, you must contact your authorized Sonance Dealer/Installer or call Sonance Customer Service at (949) 492-7777 within the warranty period, must obtain a return merchandise number (RMA), and must deliver the Product to Sonance shipping prepaid during the warranty period, together with the original sales receipt, or invoice or other satisfactory proof of purchase.

Warranty Process: Please follow the troubleshooting instructions in this manual or work with your Sonance dealer to determine the exact nature of the fault. Sonance provides a 5-Year Limited Warranty to the original owner with proof of purchase from an authorized Sonance dealer. The warranty does not cover shipping charges back to Sonance or the use of the product in an environment or application not approved by Sonance.

In order to initiate a warranty claim:

1. Contact Sonance Technical Support with a description of the fault, the amplifier's serial number and the date of purchase from an authorized Sonance dealer at: technicalsupport@sonance.com
2. Sonance Technical Support will follow-up and may request additional troubleshooting.
3. Once a determination has been made on the fault, Sonance Customer Service will follow-up by email. Please have a scanned copy of your sales invoice ready to send upon request to document the amplifier's warranty status.
4. Sonance Customer Service will provide an RMA number to be included on the shipping label of the packaging. Please send the product back in its original factory carton, which has been specifically designed to protect the product during transit.

Contact us at: <https://www.sonance.com/company/contact>

SONANCE

©2024 Sonance. All rights reserved. Sonance is a registered trademarks of Dana Innovations. Due to continuous product improvement, all features and specifications are subject to change without notice. For the latest Sonance product specification information visit our website: www.sonance.com

SONANCE · 991 Calle Amanecer · San Clemente, CA 92673 USA · PHONE: (949) 492-7777 · FAX: (949) 361-5151 · Technical Support: (949) 492-7777
01.17.2024